

Events and Their Aftermath

David Gibson

University of Pennsylvania

Antemath

Aftermath

Option A

Option B

Option C

Option C

Option D

Option E



Objects

Roads

Power lines

People

Hard currency

Buildings

Events

Riots → Crackdowns

Elections → Transfers of power

Questions → Answers

Marriages → Divorces

Battles → Surrenders

Conferences →



Sequential dependencies

4 studies

1. Networks and conversation

2. Syntax and interruption

3. Queuing

4. Scheduling and diffusion

Sequential
dependencies

Limitations on
concurrency

1. Network effects on group conversation

- Sequential dependencies in conversation are especially stark.
- Conversational options are constantly changing.
- 2 consequences
 1. The meaning of an action depends on its sequential context.
 2. We have to control for sequential openings when studying “permeation.”

Key

 First speaker

 Second speaker

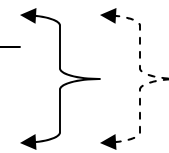
 Remark to group

Participation shift inventory

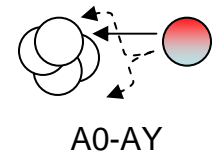
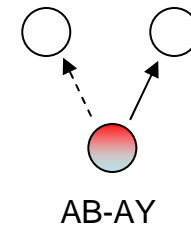
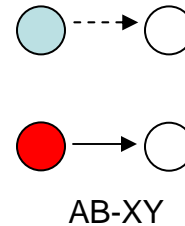
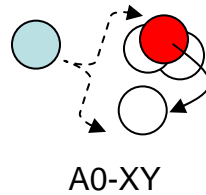
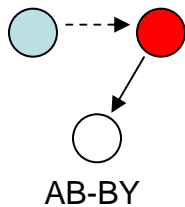
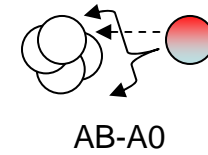
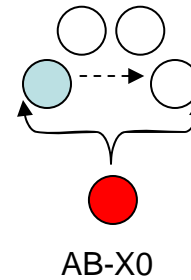
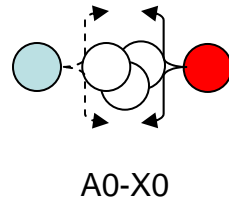
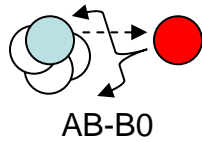
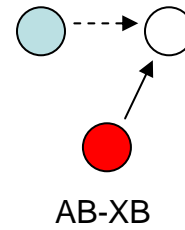
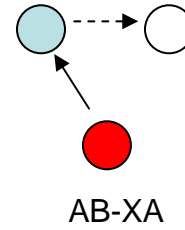
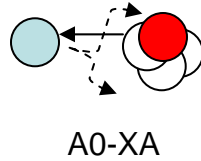
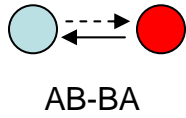

Statistical test

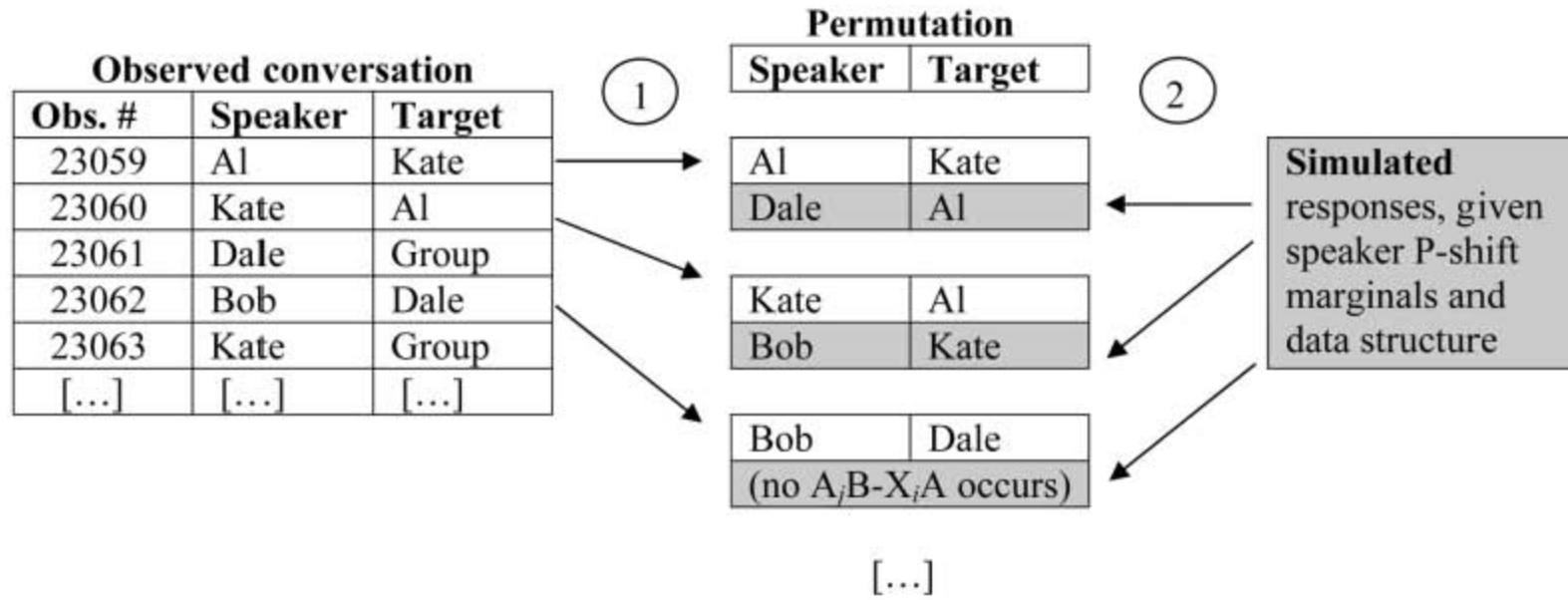

Receiving

Claiming

Usurping

Continuing

work with

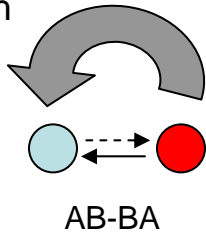

work with,
friend

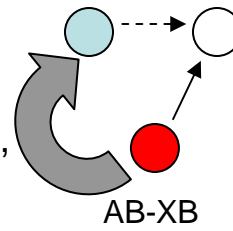

work with

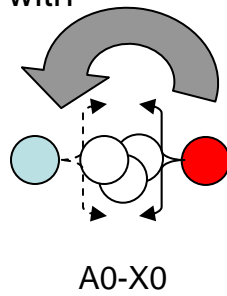

friend

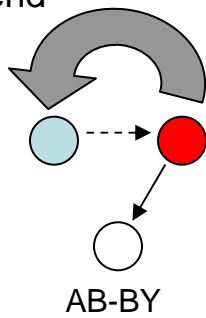

2. Interruptions and syntax

- A thought has to be “linearized” into a string of words.
- What gets said later modifies the meaning of what was said earlier.
- Prior to planned completion, the intent of an utterance can be misconstrued.
- The result: “opportunistic interruptions”—when you deliberately shape “what happened last” so as to deliver an advantageous response.
- Method: conversation analysis of Pentagon press conferences and Supreme Court oral arguments.

(topic: Iraqi exiles scheduled for training and deployment on battlefield)

(1) Pentagon May 1 38:08



<http://www.soc.upenn.edu/~gibson/Extract%201.wav>

Rumsfeld: there there are plenty of people who are anxious to participate and assist in the humanitarian aspects of it, .hhh and in terms of training more people at this stage it just didn't uh I am assuming it just di[dn't]

Journalist: [i-] is it a money problem or is it a=

Myers: → =it's not a money problem. ah it's it's more of a timing problem trying to get thee u:h .hhhh thee additional forces that we wanted to get ((...))

(6) Pentagon 3/28/03 36:00  <http://www.soc.upenn.edu/~gibsond/Extract%206.wav>

Journalist: (how does that) complicate your effort to deal with
baghdad though (.5) cut off the head of the regime .hh if
you don't have a good sense (.7) that there are any
significant number of iraqi
peo[ple ()]

Rumsfeld: → [we do] have a sense. (.8)

Journalist: s- (you) [()]

Rumsfeld: [we have] people inside talking to people, (.)
dealing with people, .hh arranging things, (.5) we have a
good sense. (.3) not of everybody because we don't have
gallup polls goin' on in there, ((laughter)) ((...))

3. Line formation

- Development through terminal addition.
- What counts as being “in line” depends on the actions of those who arrived earlier (encoded in physical line).
- Line-joining rules result in distinct line morphologies.
- Geometric continuity punctuated by redirections

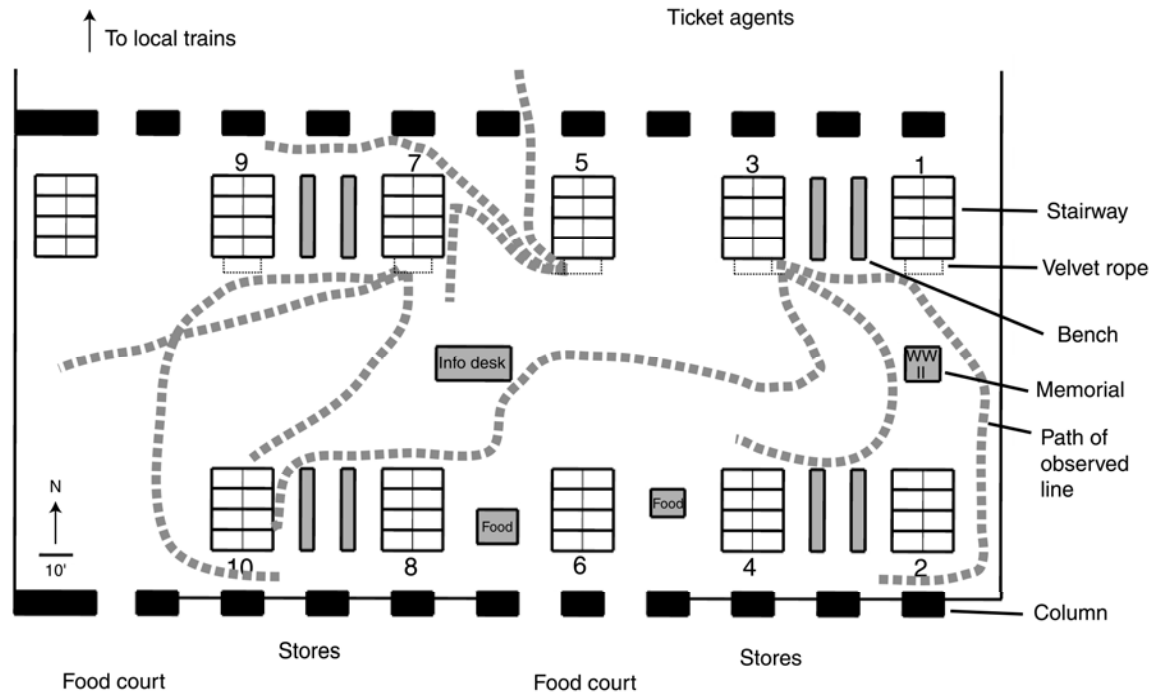

Conditions favoring redirection

1. Near physical obstacle



2. After group joins

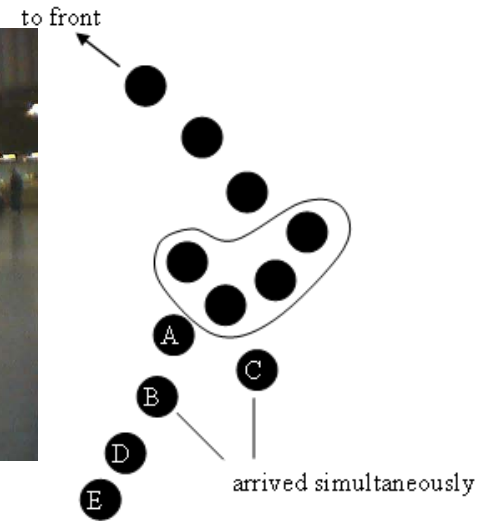

3. Belated ratification

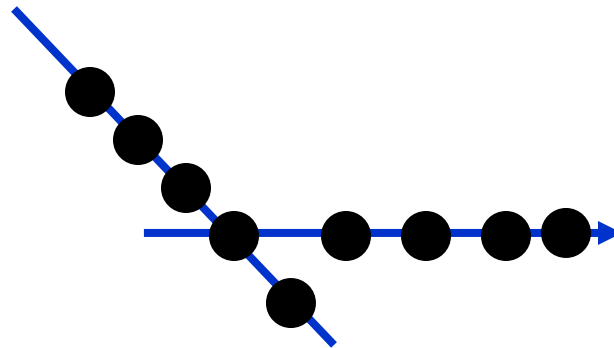

4. Scheduling and network diffusion

- Concurrency constraints—when one thing happens at the expense of another.
- Insofar as network diffusion requires dedicated encounters, scheduling intervenes.
- Methodology: computer simulation

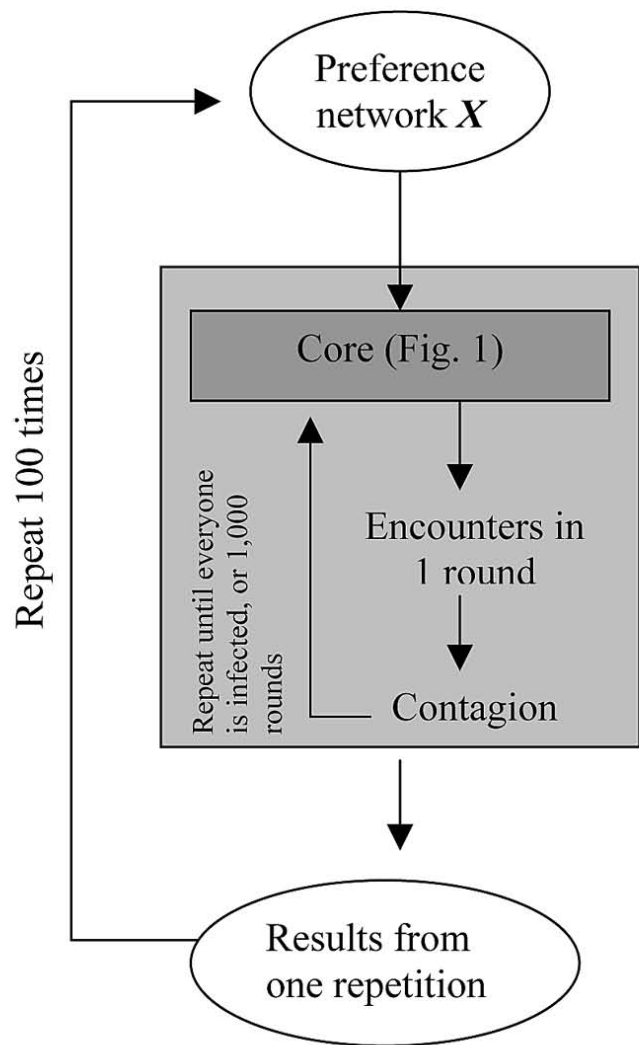

Scheduling procedure:

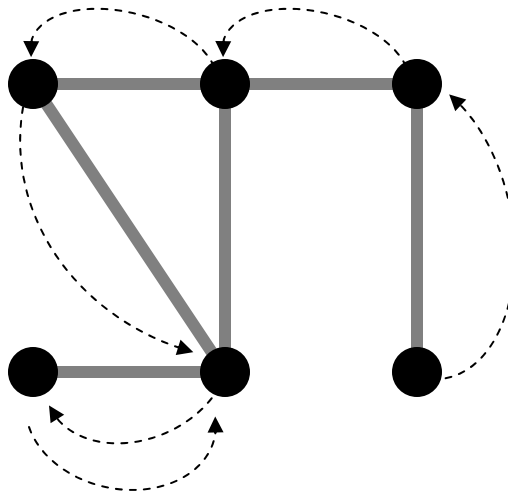

1. Everyone sends out 1 invitation to a friend.

Scheduling procedure:

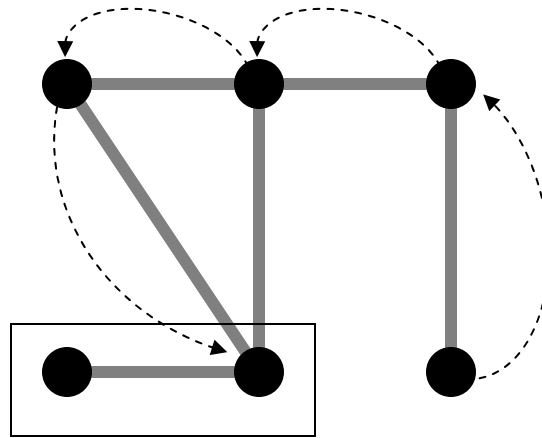

2. Pairing of reciprocal inviters and withdraw of other invitations to them.

Scheduling procedure:

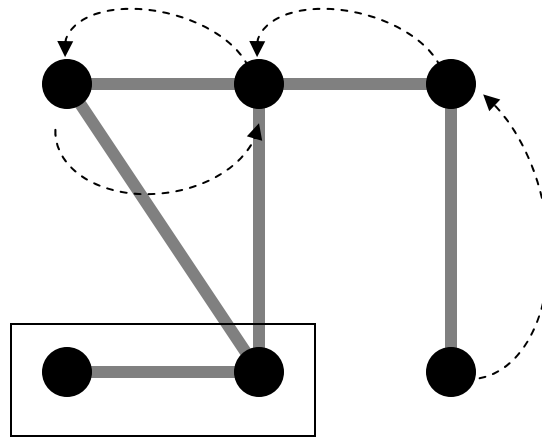

3. New invitations sent
by anyone just turned
down.

Scheduling procedure:

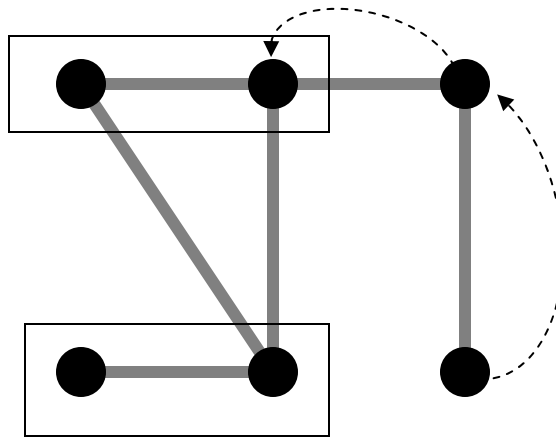

4. New pairings;
invitations withdrawn.

Scheduling procedure:

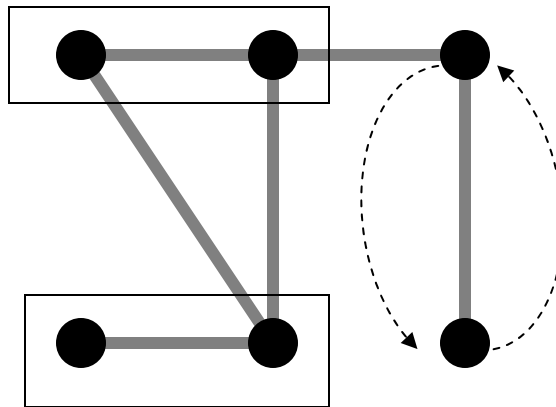

5. New invitation sent.

Scheduling procedure:

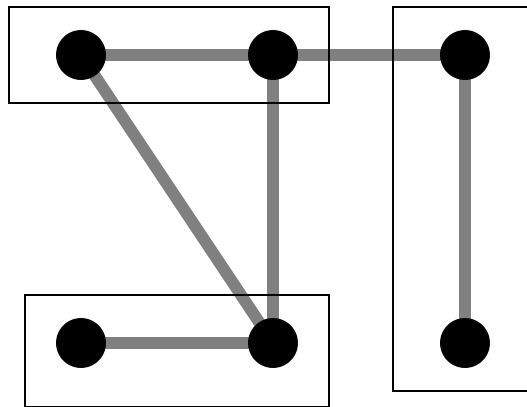

5. Final pairings.

Variations

- Normal vs. remediative scheduling
- First contact vs. threshold contagion*
- Random vs. biased network

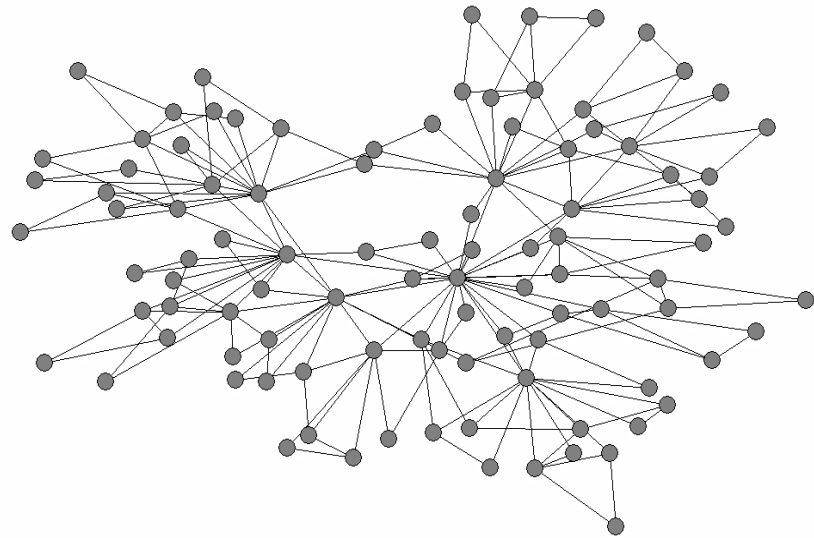
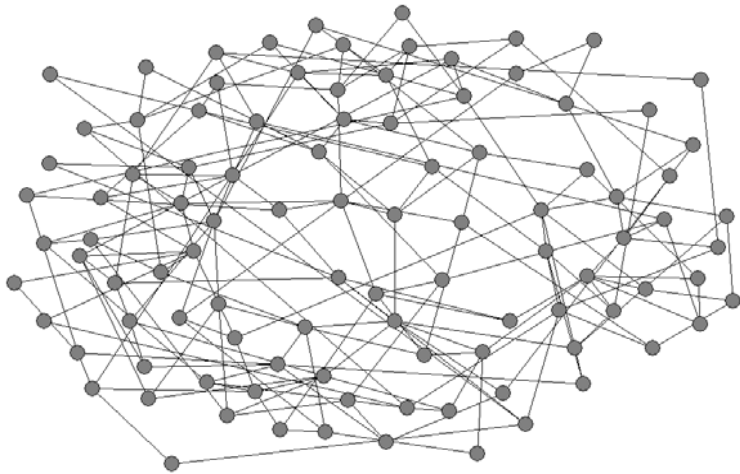

Findings

A. First contact contagion

1. Remediation expedites diffusion—makes you into a more persistent spreader.
2. Diffusion is faster in random than in biased networks—no central actors causing bottlenecks.

B. Threshold contagion

1. Remediation *impedes* diffusion—actors less likely to “misread” their networks.
2. Diffusion is faster in *biased* networks—because of low-degree actors whose thresholds are more easily reached.

In general: diffusion depends on interaction of scheduling, network structure, and contagion mechanism

Prospects for a physics of society

- What's appealing in physics
 1. Specific concepts
 - a. Field
 - b. Phase transition
 2. General orientation
 - a. Unconcern for commonsense
 - b. Precision
 - c. Accumulation
- Obstacles
 1. Heterocatalysis as important as homocatalysis.
 2. Nothing's ever demonstrated once and for all.
 3. Biology may be constant but culture is not.
 4. Strategies and metastrategies change system dynamics.